

# Jenx Dreama

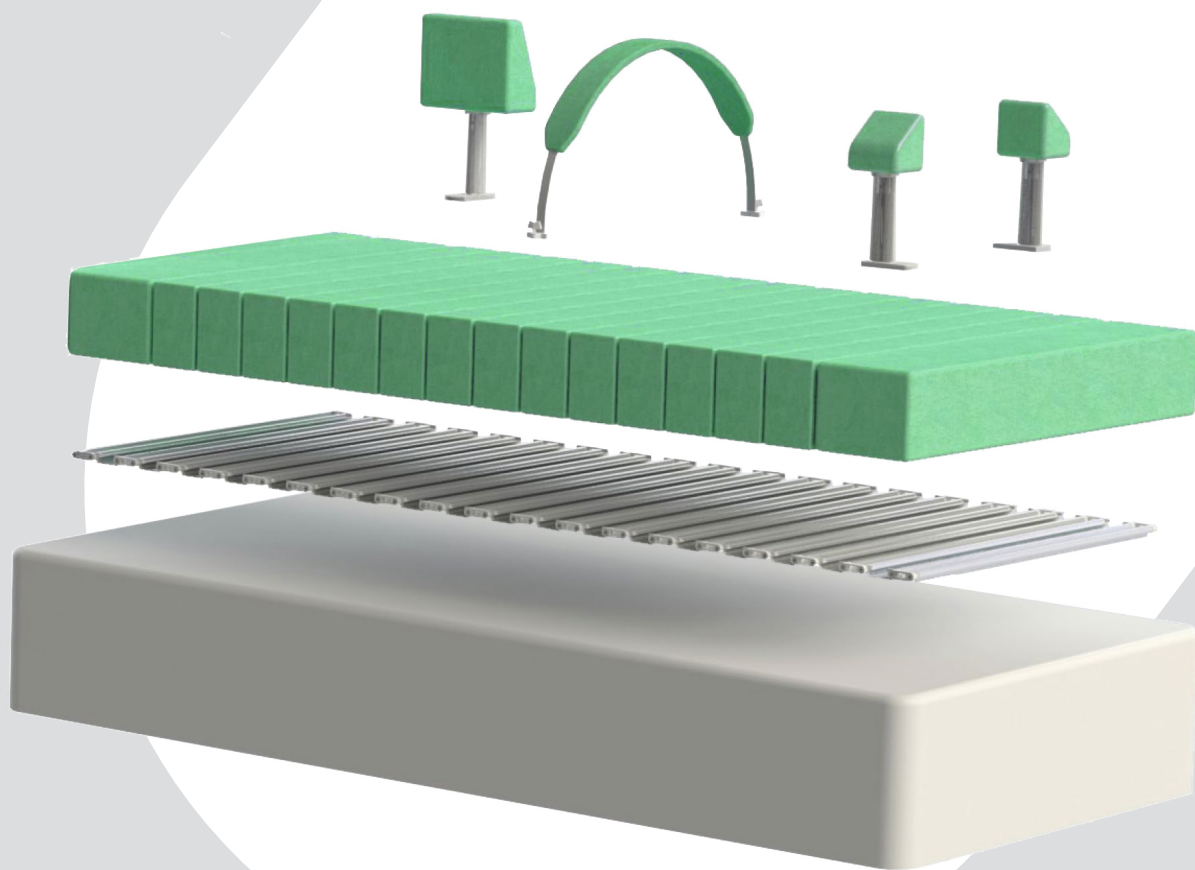

**24 HOUR  
POSITIONING SYSTEM**

Distributed by  
**medifab**

SCRIPTING AND ORDERING GUIDE

# Client Details

<b>Client/User Name:</b>		<b>Therapist Name:</b>	
<b>Clients DOB:</b>		<b>Address:</b>	
<b>Gender:</b>			
<b>Phone Number:</b>			
<b>Parent/Caregiver:</b>			
<b>Application Reference:</b>		<b>Therapist Phone:</b>	
<b>Date:</b>		<b>Therapist Mobile:</b>	
<b>NDIS/Funding:</b>		<b>Therapist Email:</b>	
<b>Notes:</b>			

Items outlined in blue are required as standard package

# Dreama Base Unit

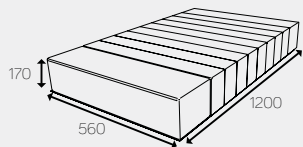
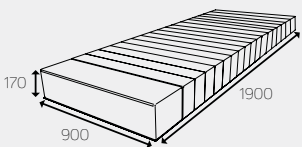
Cot Size	Standard Size
Includes: Securement straps, base frame, towelling-covered cushion cells and extra cover set.	
	
8 single, 2 double cells. 7120-0010-000	15 single, 2 double cells. 7120-0020-000
<b>Extra Cover (ea) - Single</b> 7120-2401-000	<b>Extra Cover (ea) - Single</b> 7120-2410-000
<b>Extra Cover (ea) - Double</b> 7120-2402-000	<b>Extra Cover (ea) - Double</b> 7120-2420-000

# Support Pad Combos

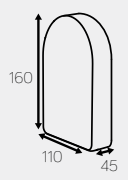
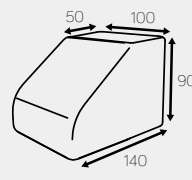
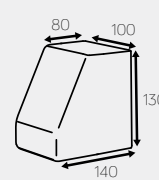
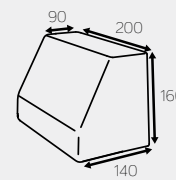
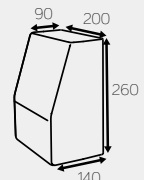
Slimline	Small	Medium	Large	Extra Large
Includes: 360° rotation pad, cover, memory foam				
				
(fixed angle) Qty: <input type="text"/> 7120-3250-500	Qty: <input type="text"/> 7120-3251-500	Qty: <input type="text"/> 7120-3252-500	Qty: <input type="text"/> 7120-3253-500	Qty: <input type="text"/> 7120-3254-500
<b>Extra Cover (ea)</b> 7120-3280-000	<b>Extra Cover (ea)</b> 7120-3281-000	<b>Extra Cover (ea)</b> 7120-3282-000	<b>Extra Cover (ea)</b> 7120-3283-000	<b>Extra Cover (ea)</b> 7120-3284-000

# Optional Add-ons

## Locking Feet

Used to mark the position where an accessory should be placed. It also keeps accessories in place for users with high movement.  
7120-6100-000

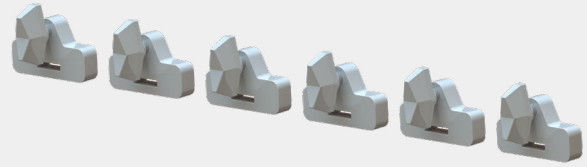

## Abduction Block

**Small**  
(Angle adjustable)

7120-1601-000

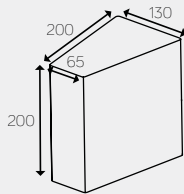

**Medium**  
(Angle adjustable)

7120-1602-000

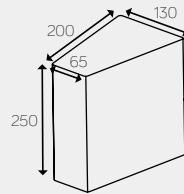

**Large**  
(Fixed)

7120-1603-000

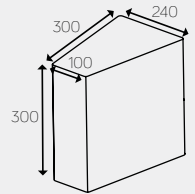

**Extra Cover**  
7120-1661-000

**Extra Cover**  
7120-1662-000

**Extra Cover**  
7120-1663-000

## Adjustable T-Roll

**One Size**

7120-1771-000

**Extra Cover**  
7120-1761-000

## Foot Support

**One Size**

Angle Adjustable  
7120-5150-000



## Support Pad

**One Size**

7120-3240-000

**Extra Cover (ea)**  
7120-3280-000



## Knee Cups (pair)

**Small**

7120-1751-000

**Extra Cover**  
7120-1781-000

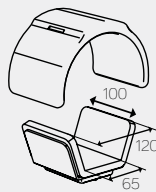

**Large**

7120-1753-000

**Extra Cover**  
7120-1783-000

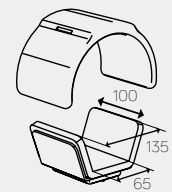

# Optional Add-ons

## Side Lying Pad

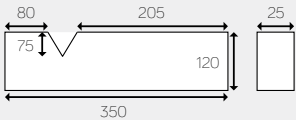
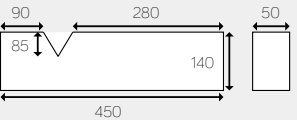
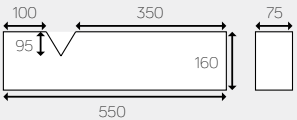
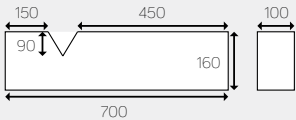
 <p>Diagram showing dimensions for Size 1: 80 (width), 75 (depth), 205 (length), 120 (height), 25 (thickness), and 350 (total length).</p>	 <p>Diagram showing dimensions for Size 2: 90 (width), 85 (depth), 280 (length), 140 (height), 50 (thickness), and 450 (total length).</p>	 <p>Diagram showing dimensions for Size 3: 100 (width), 95 (depth), 350 (length), 160 (height), 75 (thickness), and 550 (total length).</p>	 <p>Diagram showing dimensions for Size 4: 150 (width), 90 (depth), 450 (length), 160 (height), 100 (thickness), and 700 (total length).</p>
<p><b>Size 1</b> 7120-1851-000</p>	<p><b>Size 2</b> 7120-1852-000</p>	<p><b>Size 3</b> 7120-1853-000</p>	<p><b>Size 4</b> 7120-1854-000</p>
<p><b>Extra Cover</b> 7120-1861-000</p>	<p><b>Extra Cover</b> 7120-1862-000</p>	<p><b>Extra Cover</b> 7120-1863-000</p>	<p><b>Extra Cover</b> 7120-1864-000</p>

## Side Lying Strap

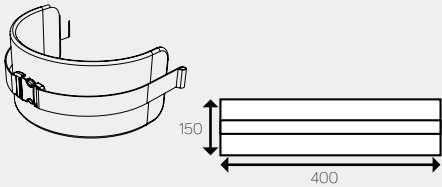
<p><b>One Size</b> 7120-1872-000</p>  <p>Diagram showing dimensions for One Size: 150 (width) and 400 (length).</p>
<p><b>Extra Cover</b> 7120-1882-000</p>

## Positioning Hoop

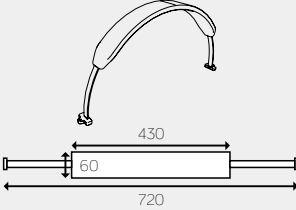
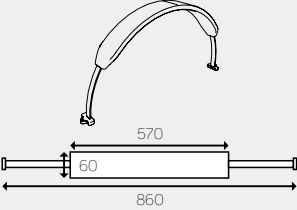
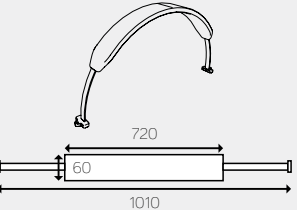
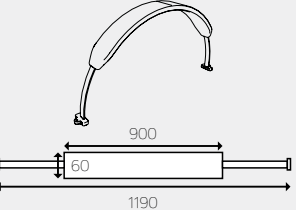
 <p>Diagram showing dimensions for Small: 430 (width), 60 (depth), and 720 (total length).</p>	 <p>Diagram showing dimensions for Medium: 570 (width), 60 (depth), and 860 (total length).</p>	 <p>Diagram showing dimensions for Large: 720 (width), 60 (depth), and 1010 (total length).</p>	 <p>Diagram showing dimensions for Extra Large: 900 (width), 60 (depth), and 1190 (total length).</p>
<p><b>Small</b> 7120-1951-000</p>	<p><b>Medium</b> 7120-1952-000</p>	<p><b>Large</b> 7120-1953-000</p>	<p><b>Extra Large</b> 7120-1954-000</p>
<p><b>Extra Cover</b> 7120-1961-000</p>	<p><b>Extra Cover</b> 7120-1962-000</p>	<p><b>Extra Cover</b> 7120-1963-000</p>	<p><b>Extra Cover</b> 7120-1964-000</p>

medifab

solutions@medifab.com

medifab.com



DISTRIBUTED BY: